

High/Low Voltage Power Capacitors



INTEGRATION
OF POWER SYSTEM



Contents

High voltage power capacitors

High voltage capacitors-internal fuse type	2
High voltage capacitors-standard type (non-internal fuse)	9
Coefficients calculation on capacitance variation after increase Of high voltage capacitor voltage	15
Series reactor selection after increase of capacitor's voltage	16
Operation Notes	17
Maintenance and service for the high voltage capacitors	17

Low voltage power capacitors

Low voltage explode-proof power capacitor KS	20
Low voltage explode-proof power capacitor KJ	24
Low voltage explode-proof power capacitor KR	27
Harmonic-resistant capacitor series	30
μ f type indoor capacitor series	32
Low voltage power dry type H class reactor series	34
Series reactor selection after increase of capacitor diagnose	38
Low voltage power capacitors general inspection and gauge	38
Low Voltage Capacitor's Maintenance	40
Capacitance coefficients calculation on capacitors to be installed	40
Coefficients calculation on capacitance variation After Increase Of Low Voltage Capacitor Voltage	42

High voltage power capacitors

High Voltage Capacitors-Internal Fuse Type

Advantages - Operation will continue after the fuses are actuate

With Internal Fuse Type

When one capacitor element inside the power capacitor breaks down, the internal fuse will rapidly cut off, and remove malfunction element so the operation will not be interrupted.

Standard Type

When one capacitor elemen inside the capacitor breaks down, the external protective fuse will rapidly cut off, and stop operation. Whole power capacitor must be replaced.

The decrease of capacitance is insignificant

With Internal Fuse Type

When the fuse of an internal capacitor element cuts off, only its capacitance will be lost.

Standard Type

For the standard, the total capacitance of entire power capacitor will be lost even there is only one capacitor element breaks down.

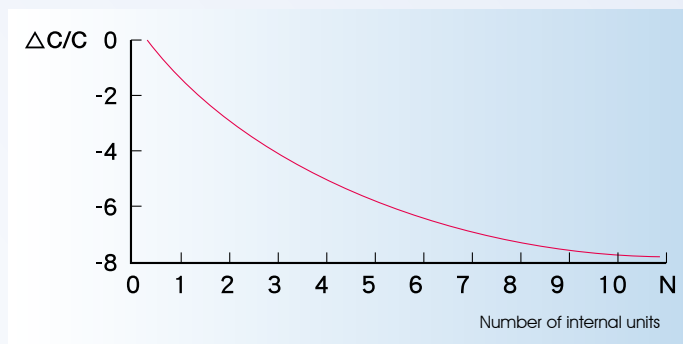

Smaller installation space

With Internal Fuse Type

Installation space for the internal fuse type capacitor can be drastically decreased because it can be linked directly with conductors into n type in parallel connection. It is particularly suitable for installing in a panel and the cost for power distribution equipment can be saved.

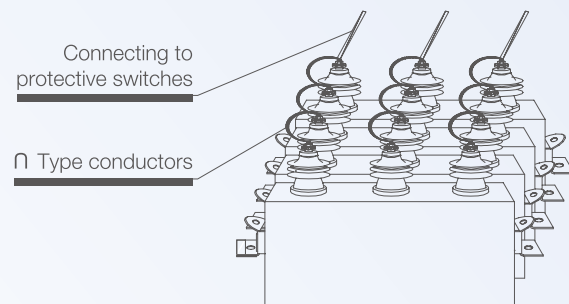

Standard Type

To compliance with the Electro-technical Codes, Art. 436, a conventional type capacitor must be installed with support insulators for the bus bars and further fitted with tension fuses. Consequently larger installation space are required.

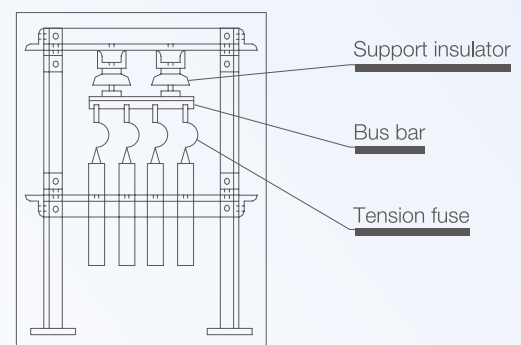

Internal type and standard type capacitors comparisons summary

Item	Internal Fuse Type	Conventional Type
Installation space	Small	Larger
Continuous usability after actuation of one element	Excellent	Depends on different condition
Reactive power loss	Low	Average
Imbalance protection	Good	Average
Fuse Protection	Good	Average
Case breakdown possibility	Low	Average
Fuse misoperation possibility	Low	Average

Specifications and Performances

Installation Location	Both indoor and outdoor
Ambient Temperature	- 20°C~ + 40°C (24-hr average:lower than 35°C)
Max. Working Voltage	Within 110% rated voltage (24-hr average:lower than 110%)
Max. Working Current	Within 135% rated current (including high harmonic wave and manufacturing tolerance)
Capacity Tolerance	- 5%~ + 10% of rated value (within 3% phase-to-phase tolerance)
Loss	Less than 0.35% at 20°C
Temperature Rise	Lower than 25°C when ambient temperature is lower than 40°C
Sealing	No trace of oil leaking outside of capacitor case after heating in constant temperature tank at 80±5°C for 4 hrs
Discharge	With built-in discharge resistor, residual voltage drops to lower than 50V after capacitor is disconnected from power for 5 minutes
Safety	Excellent, due to individual fuse protection for every single unit inside the capacitor.
Standards	CNS 1372 and 3739 · JIS C4902



Diagram Dimensions

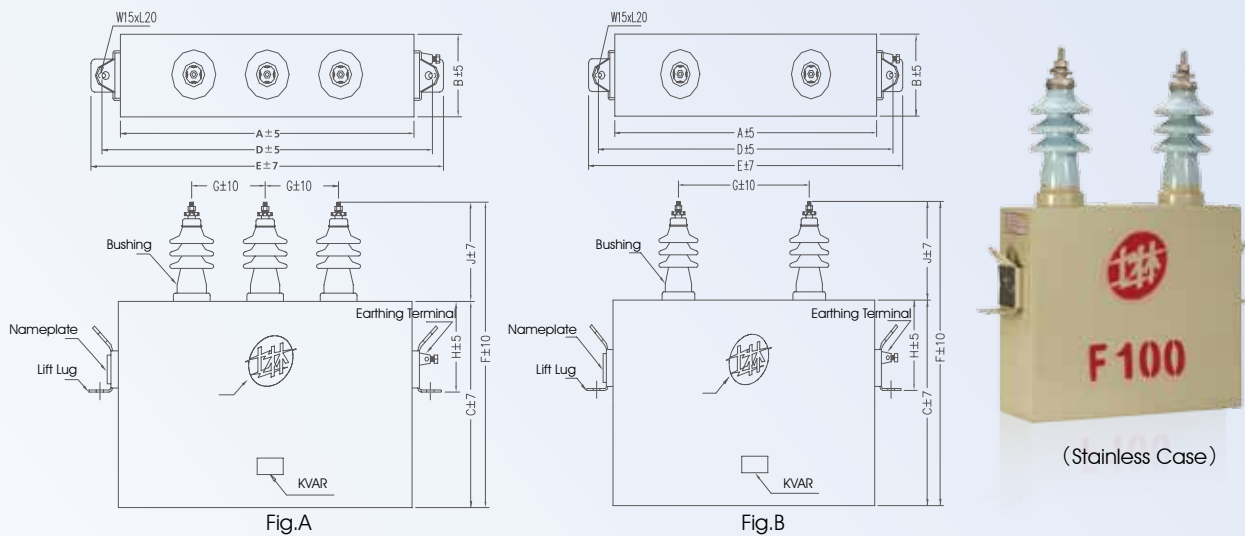

For capacitors not listed in below specifications tables, or compound capacitors made up of several units as well as associate steel mountings, switches, protective equipment etc., Shihlin Electric can also provide design and manufacturing services.

Table of 3Ø · 60Hz · 3600V High Voltage Capacitors - Internal Fuse Type (suit for 3300V system)

Type	Capacity KVAR	Current A	Fig	Dimensions (mm)									Approx. Weight(kg)
				A	B	C	D	E	F	G	H	J	
SPF-03606100T	100	16.0	A	430	130	300	486	530	470	150	150	170	28
SPF-03606150T	150	24.1	A	430	130	450	486	530	620	150	150	170	39
SPF-03606200T	200	32.1	A	530	130	450	586	630	620	200	150	170	50
SPF-03606250T	250	40.1	A	530	170	450	586	630	620	200	150	170	62
SPF-03606300T	300	48.1	A	630	170	450	686	730	620	250	150	170	72

Table of 3Ø · 60Hz · 12800V High Voltage Capacitors - Internal Fuse Type (suit for 11400V system)

Type	Capacity KVAR	Current A	Fig	Dimensions (mm)									Approx. Weight(kg)
				A	B	C	D	E	F	G	H	J	
SPF-12806100T	100	4.5	A	430	130	300	486	530	536	150	150	236	29
SPF-12806150T	150	6.8	A	430	130	450	486	530	686	150	150	236	40
SPF-12806200T	200	9.0	A	530	130	450	586	630	686	200	150	236	51
SPF-12806250T	250	11.3	A	530	170	450	586	630	686	200	150	236	63
SPF-12806300T	300	13.5	A	630	170	450	686	730	686	250	150	236	73



Table of 1 \emptyset , 60Hz , 14700V High Voltage Capacitors - Internal Fuse Type (suit for 22800V system)

Type	Capacity KVAR	Current A	Fig	Dimensions (mm)									Approx. Weight(kg)
				A	B	C	D	E	F	G	H	J	
SPF-14706100S	100	6.8	B	340	110	450	396	440	731	200	150	281	29
SPF-14706150S	150	10.2	B	340	150	450	396	440	731	200	150	281	40
SPF-14706200S	200	13.6	B	430	170	450	486	530	731	200	150	281	53
SPF-14706250S	250	17.0	B	530	170	450	586	630	731	200	150	281	63
SPF-14706300S	300	20.4	B	630	170	450	686	730	731	300	150	281	73

Table of 3 \emptyset , 60Hz , 25400V High Voltage Capacitors - Internal Fuse Type (suit for 22800V system)

Type	Capacity KVAR	Current A	Fig	Dimensions (mm)									Approx. Weight(kg)
				A	B	C	D	E	F	G	H	J	
SPF-25406100T	100	2.3	A	630	110	300	686	730	581	250	150	281	39
SPF-25406150T	150	3.4	A	630	150	300	686	730	581	250	150	281	49
SPF-25406200T	200	4.6	A	630	130	450	686	730	731	250	150	281	62
SPF-25406250T	250	5.7	A	630	150	450	686	730	731	250	150	281	69
SPF-25406300T	300	6.8	A	630	170	450	686	730	731	250	150	281	76

High Voltage Capacitors-Standard Type (Non-Internal Fuse)

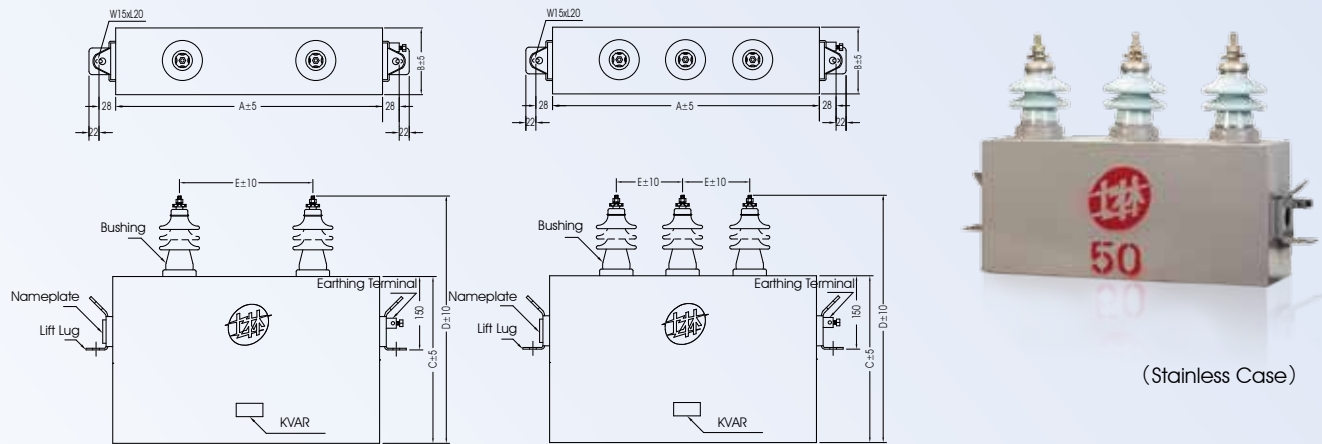

(Stainless Case)

Specifications and Performances

Installation Location	Both Indoor and Outdoor
Ambient Temperature	- 20°C - + 40°C (24-hr average: lower than 35°C)
Max. Working Voltage	Within 110% rated voltage (24-hr average: lower than 110%)
Max. Working Current	Within 135% rated current (including high harmonic wave and manufacturing tolerance)
Capacity Tolerance	- 5% + 10% of rated value (within 3% phase-to-phase tolerance)
Loss	Less than 0.35% at 20°C
Temperature Rise	Lower than 25°C when ambient temperature is lower than 40°C
Sealing	No trace of oil leaking outside of capacitor case after heating in constant temperature tank at 80 ± 5°C for 4 hrs
Discharge	With built-in discharge resistor, residual voltage drops to lower than 50V after capacitor is disconnected from power for 5 minutes
Standards	CNS 1372 and 3739 · JIS C4902

Table of 3Ø, 60Hz, 3450V High Voltage Power Capacitors (suit for 3300V system)

Type	Rated Voltage	Capacity		Current(A)	Fig.	Dimensions(mm)					Approx. weight(kg)	Applicable Environment
		KVAR	μF			A	B	C	D	E		
SPO-03456050T		50	11.14	8.4	A	430	130	210	380	150	19	<ul style="list-style-type: none"> ● System Voltage : 3300V · Equipped with SC circuit which leads to switch less flipping. · With extremely low harmonic.
SPO-03456075T		75	16.71	12.6	A	430	110	300	470	150	23	
SPO-03456100T		100	22.29	16.7	A	430	130	300	470	150	26	
SPO-03456150T	3450V	150	33.43	25.1	A	430	130	450	620	150	37	
SPO-03456200T		200	44.57	33.5	A	530	130	450	620	200	48	
SPO-03456250T		250	55.71	41.8	A	530	150	450	620	200	55	
SPO-03456300T		300	66.86	50.2	A	630	150	450	620	250	63	

Table of 3Ø , 60Hz , 4160V High Voltage Power Capacitors (suit for 4160V system)

Type	Rated Voltage	Capacity		Current(A)	Fig.	Dimensions(mm)					Approx. weight(kg)	Applicable Environment
		KVAR	μ F			A	B	C	D	E		
SPO-04166050T	4160V	50	7.66	6.9	A	430	130	210	380	150	19	<ul style="list-style-type: none"> ● System Voltage : 4160V · Equipped with SC circuit which leads to switch less flipping. · With extremely low harmonic.
SPO-04166075T		75	11.50	10.4	A	430	110	300	470	150	23	
SPO-04166100T		100	15.33	13.9	A	430	130	300	470	150	26	
SPO-04166150T		150	22.99	20.8	A	430	130	450	620	150	37	
SPO-04166200T		200	30.66	27.8	A	530	130	450	620	200	48	
SPO-04166250T		250	38.32	34.7	A	530	150	450	620	200	55	
SPO-04166300T		300	45.98	41.6	A	630	150	450	620	250	63	

Table of 3Ø , 60Hz , 11950V High Voltage Power Capacitors (suit for 11400V system)

Type	Rated Voltage	Capacity		Current(A)	Fig.	Dimensions(mm)					Approx. weight(kg)	Applicable Environment
		KVAR	μ F			A	B	C	D	E		
SPO-11956050T	11950V	50	0.93	2.4	A	430	130	210	446	150	21	<ul style="list-style-type: none"> ● System Voltage : 11400V · Equipped with SC circuit which leads to switch less flipping. · With extremely low harmonic.
SPO-11956075T		75	1.39	3.6	A	430	110	300	536	150	25	
SPO-11956100T		100	1.86	4.8	A	430	130	300	536	150	28	
SPO-11956150T		150	2.79	7.2	A	430	130	450	686	150	39	
SPO-11956200T		200	3.71	9.7	A	530	130	450	686	200	50	
SPO-11956250T		250	4.64	12.1	A	530	150	450	686	200	57	
SPO-11956300T		300	5.57	14.5	A	630	150	450	686	250	65	

Table of 3Ø , 60Hz , 13800V High Voltage Power Capacitors (suit for 11400V system)

Type	Rated Voltage	Capacity		Current(A)	Fig.	Dimensions(mm)					Approx. weight(kg)	Applicable Environment
		KVAR	μ F			A	B	C	D	E		
SPO-13806050T	13800V	50	0.70	2.1	A	430	130	210	446	150	21	<ul style="list-style-type: none"> ● System Voltage : 11400V · If series reactor L= 6%、8% and 13%, the harmonic will be higher and cause voltage to rise.
SPO-13806075T		75	1.04	3.1	A	430	110	300	536	150	25	
SPO-13806100T		100	1.39	4.2	A	430	130	300	536	150	28	
SPO-13806150T		150	2.09	6.3	A	430	130	450	686	150	39	
SPO-13806200T		200	2.79	8.4	A	530	130	450	686	200	50	
SPO-13806250T		250	3.48	10.5	A	530	150	450	686	200	57	
SPO-13806300T		300	4.18	12.6	A	630	150	450	686	250	65	

Table of 3Ø , 60Hz , 23900V High Voltage Power Capacitors (suit for 22800V system)

Type	Rated Voltage	Capacity		Current(A)	Fig.	Dimensions(mm)					Approx. weight(kg)	Applicable Environment
		KVAR	μ F			A	B	C	D	E		
SPO-23906050T	23900V	50	0.23	1.2	A	630	110	210	491	250	26	<ul style="list-style-type: none"> ● System Voltage : 22800V · Equipped with SC circuit which leads to switch less flipping. · With extremely low harmonic.
SPO-23906075T		75	0.35	1.8	A	630	130	210	491	250	30	
SPO-23906100T		100	0.46	2.4	A	630	150	210	491	250	32	
SPO-23906150T		150	0.70	3.6	A	630	130	300	581	250	42	
SPO-23906200T		200	0.93	4.8	A	630	170	300	581	250	50	
SPO-23906250T		250	1.16	6.0	A	630	130	450	731	250	62	
SPO-23906300T		300	1.39	7.2	A	630	150	450	731	250	67	

Table of 3Ø , 60Hz , 25400V High Voltage Power Capacitors (suit for 22800V system)

Type	Rated Voltage	Capacity		Current(A)	Fig.	Dimensions(mm)					Approx. weight(kg)	Applicable Environment
		KVAR	μ F			A	B	C	D	E		
SPO-25406050T	25400V	50	0.21	1.1	A	630	110	210	491	250	26	<ul style="list-style-type: none"> ● System Voltage : 22800V · If series reactor L= 6%、8% and 13%, the harmonic will be higher and cause voltage to rise.
SPO-25406075T		75	0.31	1.7	A	630	130	210	491	250	30	
SPO-25406100T		100	0.41	2.3	A	630	150	210	491	250	32	
SPO-25406150T		150	0.62	3.4	A	630	130	300	581	250	42	
SPO-25406200T		200	0.82	4.5	A	630	170	300	581	250	50	
SPO-25406250T		250	1.03	5.7	A	630	130	450	731	250	62	
SPO-25406300T		300	1.23	6.8	A	630	150	450	731	250	67	

(3) Coefficients Calculation On Capacitance Variation After Voltage Increase.

System Voltage(KV)	(KV) Intended increase of rated voltage (KV) for the capacitor											
	3.45	3.8	4.0	4.16	4.6	4.8	11.95	12.8	13.8	23.9	25.4	27.5
3.3	1.093	1.326	1.469	1.589	1.943	2.116	-	-	-	-	-	-
4.16	-	-	-	-	1.223	1.331	-	-	-	-	-	-
11.4	-	-	-	-	-	-	1.099	1.261	1.465	-	-	-
22.8	-	-	-	-	-	-	-	-	-	1.099	1.241	1.455

Example of application

Assuming the system voltage is 11.4KV, the required capacitance is 100KVAR. Taking into consideration of voltage rise due to series reactor or high harmonic content, the actual capacitance as follows:

Required capacitor capacitance = 100 X 1.261 (obtained from above table) = 126.1KVAR

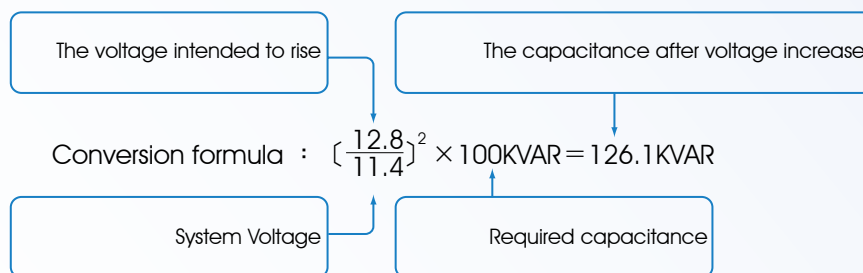



(4) Series Reactor Selection After Increase Of Capacitor Voltage



Wrong Series Reactor
System Voltage 3.3KV

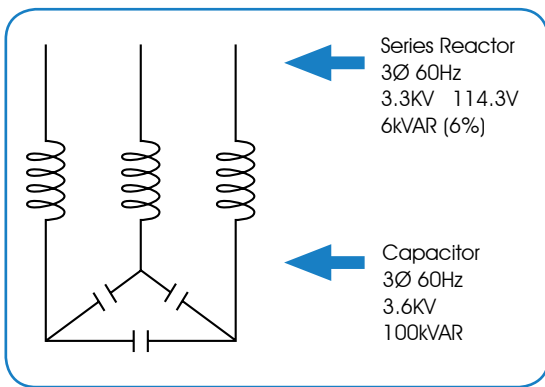

The rated voltages of reactor and capacitor are different, the resistance ratio is 5.04% (not 6%)



Correct Series Reactor
System Voltage 3.3KV

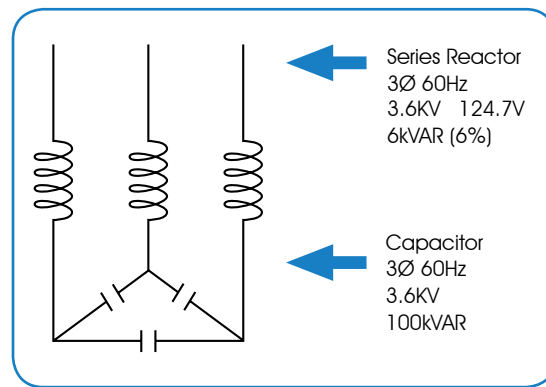

The rated voltages of reactor and capacitor are the same, the resistance ratio is 6%

Calculation of the ratio of Capacitance and Reactance

$$\begin{aligned} & (3300V/\sqrt{3}) \times 6\% = 114.3V \\ & XL = V^2 / Q = 114.3^2 / 6\text{KVAR} / 3 = 6.532 \Omega \\ & XC = V^2 / Q = 3600^2 / 100\text{KVAR} = 129.6 \Omega \\ & XL / XC = 6.532 / 129.6 = 5.04\% \end{aligned}$$

$$\begin{aligned} & (3600V/\sqrt{3}) \times 6\% = 124.7V \\ & XL = V^2 / Q = 124.7^2 / 6\text{KVAR} / 3 = 7.775 \Omega \\ & XC = V^2 / Q = 3600^2 / 100\text{KVAR} = 129.6 \Omega \\ & XL / XC = 7.775 / 129.6 = 6\% \end{aligned}$$

A suggestion is proposed here, that is to choose the reactor whose rated voltage is the same as capacitor's.

(5) Operation Notes

1. Please use the capacitors at ambient temperature within range from $-25^{\circ}\text{C} \sim +40^{\circ}\text{C}$.
2. Please do not move the capacitors by the sleeves, and never use a coin to do the parallel connection.
3. When the capacitors are installed side by side, please keep the distance between each capacitor for more than 8cm for better heat dissipation.
4. The sleeves and terminals should be kept in clean condition to avoid poor insulation, and maintenance should only be performed after being disconnected from power for more than 5 minutes.
5. System harmonic content should be taken into consideration, and voltage-withstand rating of capacitor's rated voltage should be upgraded.
6. In application of automatic power adjusting panel, because frequent throw-ins and throw-outs, please connect series reactor at each stage, and upgrade the capacitor's voltage-withstand rating.
7. To prevent damages caused by overlapping voltage, throw-in time should be set at 5 minutes after capacitor has been disconnected.
8. Capacitors should be linked with series reactors in order to suppress surges and harmonic waves. Voltage rise of the capacitor should be watched when series reactor is connected. The rise of capacitor voltage is 6.4% when a 6% series reactor is connected, and it is 15% when a 13% series reactor is connected.
9. Non-combustible insulating oil is adopted in our capacitors. Furthermore, internal fuse type meets the Electro-technical Codes, Art 436, and individual fuse protection has been provided for each capacitor element. For conventional type (Non Internal Fuse), to meet the Electro-technical codes, please use individual fuse protection for each capacitor unit to enhance safety and fire protection.

(6) Maintenance And Service For The H.V. Capacitors

1. The capacitor's ambient temperature must be lower than 40°C . At installation consider following situations: surrounding temperature rise and stability, ventilation provision, and heat source radiation. Suggest customers install capacitors in a well ventilated location
2. There are switches various kinds of protection facilities, attention must be paid to switches' contact points whether they are working properly.
3. Check whether working voltage and current are normal, over-voltage will lead to increase of capacitor's capacitance and rise of temperature. In addition to endanger the capacitor's life, the abnormal voltages will also frequently cause internal insulation components to breakdown.
4. Check the capacitor insulators and it's case when oil leaking (including breaking) is detected. The capacitor should be well covered immediately and forwarded to factory for repair. To avoid insulation oil degraded caused by oil leak and moisture buildup inside capacitor, case should be repaired immediately.
5. Check sparks or abnormalities caused by inferior contacting points between the capacitor terminals and conductors, which often result in fuse cut-outs during operation.
6. Check for other abnormal phenomena.
7. Clean up the dirt and dust on the ceramic sleeve surfaces. Dirt and dust will accumulate on the sleeve surfaces of the capacitors either installed indoor or outdoor after a long time. If moisture is absorbed, there will be inferior insulation which will lead to trip of the protective equipment and cause serious electric leakage. Clean up dirt and dust on the sleeve surfaces should only be proceeded after the capacitor is disconnected from power for more than 5 minutes, and has been discharged through ground to avoid electric shock.
8. The measured insulation resistance values between T&C, must above $1000\text{M}\Omega$.

(7) Measurement of Capacitance

1. After capacitor is fully discharged (measuring by direct reading capacitance meter).
 2. Measurement method
 - $U-V=a, V-W=c$: measuring for 3 times.
 - Total capacitance = $(a+b+c) \times 2 \div 3$
 - Conclusion ;
- * Actually measured capacitance $a \approx b \approx c$
 * Total capacitance \approx capacitance indicated on the nameplate

Direct reading capacitance meter



Low Voltage power capacitor

Characteristic

- Low loss of medium and temperature with long serving time to save electricity bill.
- This is a special green product produced by Shihlin Electric and use flame retardant EPOXY(UL-94V0) resin and seal,
- hence the oil leakage oil can be prevented so does the pollution of environment.
- The capacitor meets the CNS、JIS and IEC standards. Every individual capacitor has a internal safety device (approved by UL, E105535), when the capacitor faults, it will cut off power supply automatically to prevent the occurrence of secondary hazard.
- The capacitor is equipped with discharge resistors to ensure the safety of electrification and maintenance.
- This is an unique Eco-friendly product made by Shihlin. Sealed with Epoxy(UL-94V0) soft resin, it eliminates oil leak in operation, reduces erosion, and environmental pollution.



(1) Low voltage explode-proof power capacitor KS

Characteristic

- The capacitor is made with high-voltage endurance and excellent dielectric metallized polypropylene film. It provides self-healing function, when the film breaks, the metallized electrode around the spark hole will be evaporated and recovers insulation at the same time, so the capacitor can still work normally.
- The capacitor is sealed and put in an aluminium shell. This aluminium shell attached to inside iron case wall which provide a good heat dissipation ability and extremely slow temperature rise.
- It has sequential protection ability and high safety reliability. Each individual capacitor element is protected by pressure-type protective device and installed in a vermiculite filled case which provide fire-proof and explode-proof. Vermiculite is hard to burn and is highly compressible. Capacitors' cases are made of high strength steel material. If capacitor fails and releases large energy the vermiculite can suppress impact to keep case from deformed. This filled material act as fire sand to isolate air to possible combustion and disaster greatly prevented.
- Low loss of medium and temperature with long operation life that helps to save electricity bill.
- The capacitor is equipped with discharge resistors to ensure the safety of electrification and maintenance.
- This is an unique Eco-friendly product made by Shihlin. Filled with soft resin, it eliminates oil leak in operation, reduces erosion, and environmental pollution.

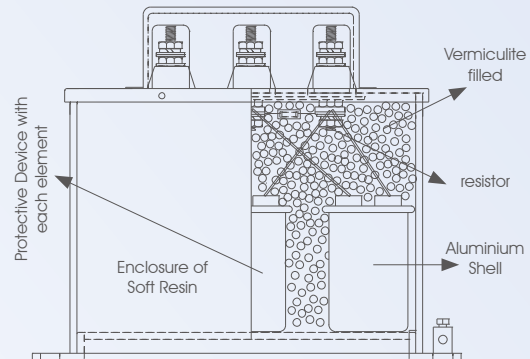

Main technical target

- Use condition: indoor, ambient temperature $-25^{\circ}\text{C} \sim +45^{\circ}\text{C}$, humidity $\leq 95\%$, below 2000m altitude
- Frequency: 60Hz(50Hz)
- Capacity tolerance: $-5\% \sim +10\%$ (between phases tolerance within $\pm 3\%$)
- Dielectric Strength: T-T 2.15VAC, T-C 3000V 10sec
- Medium loss: below 0.2W/kVAR
- Max. premissible over voltage: rated voltage * 110%
- Max. premissible over current: rated current * 130%
- Protect level: IP42
- Discharge characteristic: each capacitor unit has discharge resistor which reduces the terminal voltage of the capacitor to under 75V within 3minute after the capacitor has disconnected from power source.
- standard: IEC 60871 or JIS 4902 or CNS 1372.



Dimensions Diagram

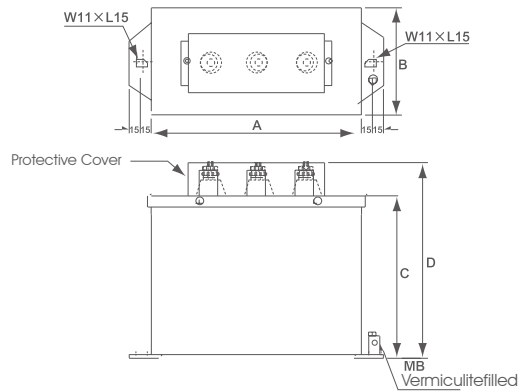

Low voltage power capacitor selection table 3Ø · 60Hz 220V 、 240V 、 260V 、 280V

Type	SYS. Voltage (VAC)	Rated Voltage		220VAC		240VAC		260VAC		280VAC		Dimensions(mm)			
		Capacity	μ F	Current (A)	μ F	Current (A)	μ F	Current (A)	μ F	Current (A)	A	B	C	D	
SH-S * * * 605T	220	5	274	13.1	230	12.0	196	11.1	169	10.3	200	75	250	324	
SH-S * * * 610T		10	548	26.2	461	24.1	392	22.2	338	20.6	200	75	250	324	
SH-S * * * 615T		15	822	39.4	691	36.1	589	33.3	507	30.9	230	130	250	324	
SH-S * * * 620T		20	1096	52.5	921	48.1	785	44.4	677	41.2	230	130	250	324	
SH-S * * * 625T		25	1370	65.6	1151	60.1	981	55.5	846	51.6	230	185	250	324	
SH-S * * * 630T		30	1644	78.7	1382	72.2	1177	66.6	1015	61.9	230	185	250	324	
SH-S * * * 635T		35	1918	91.9	1612	84.2	1373	77.7	1184	72.2	300	185	250	324	
SH-S * * * 640T		40	2192	105.0	1842	96.2	1570	88.8	1353	82.5	300	185	250	324	
SH-S * * * 645T		45	2466	118.1	2072	108.3	1766	99.9	1522	92.8	300	240	250	324	
SH-S * * * 650T		50	2740	131.2	2303	120.3	1962	111.0	1692	103.1	300	240	250	324	
SH-L * * * 655T		55	3014	144.3	2533	132.3	2158	122.1	1861	113.4	350	140	470	544	
SH-L * * * 660T		60	3288	157.5	2763	144.3	2354	133.2	2030	123.7	350	140	470	544	
SH-L * * * 665T		65	3562	170.6	2993	156.4	2550	144.3	2199	134.0	420	140	470	544	
SH-L * * * 670T		70	---	---	3224	168.4	2747	155.4	2368	144.3	420	140	470	544	
SH-L * * * 675T		75	---	---	---	---	2943	166.5	2537	154.7	420	140	470	544	
SH-L * * * 680T		80	---	---	---	---	---	---	2707	165.0	420	140	470	544	

- Applicable Environment
- System voltage: 220V, with 260V, 280V or above capacitor.
 - capacitor control led by APFR or parallel connected capacitors and high harmonic, series reactor L=6%, 7%, 13%, 15% °
 - System voltage: 220V, with 240V or above capacitor.
 - capacitor control led by APFR or parallel connected capacitors and high harmonic, series reactor L=6% °
 - system voltage: 220V with 220V or above capacitor.
 - Capacitors equipped with traditional manual on/off switch. Installed separately, seldom on/off, and no harmonic load.

· Type *** is capacitor's rated voltage. For voltage 380 ~ 525 VAC, the dimension dose not change for 5、10、20 KVAR. The capacitors with 15、25~60KVAR capacity are smaller size models.
 · Series reactors must be used In situations of using APFR control and high harmonic current. Suggest selected capacitor's rated voltage 1.25 times above system voltage. Please contact manufacturer for other special voltage or capacity capacitors.

Dimensions Diagram

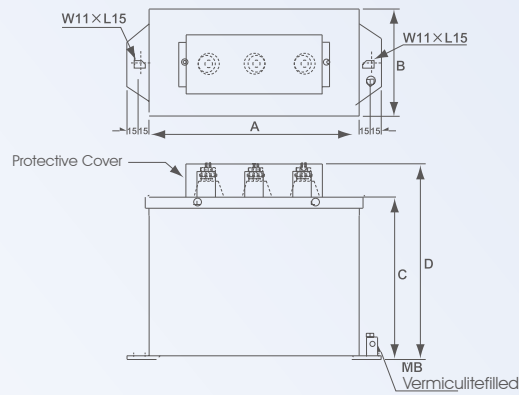

Low voltage power capacitor selection table 3Ø , 60Hz 220V 、 240V 、 260V 、 280V

Type	SYS. Voltage (VAC)	Rated Voltage	380VAC		440VAC		480VAC		525VAC		Dimensions(mm)			
			KVAR	μ F	Current (A)	μ F	Current (A)	μ F	Current (A)	μ F	Current (A)	A	B	C
SH-S * * * 605T	380	5	92	7.6	69	6.6	58	6.0	48	5.5	200	75	250	324
SH-S * * * 610T		10	184	15.2	137	13.1	115	12.0	96	11.0	200	75	250	324
SH-S * * * 615T		15	276	22.8	206	19.7	173	18.0	144	16.5	200	75	250	324
SH-S * * * 620T		20	367	30.4	274	26.2	230	24.1	192	22.0	230	130	250	324
SH-S * * * 625T		25	459	38.0	343	32.8	288	30.1	241	27.5	230	130	250	324
SH-S * * * 630T		30	551	45.6	411	39.4	345	36.1	289	33.0	230	130	250	324
SH-S * * * 635T		35	643	53.2	480	45.9	403	42.1	337	38.5	230	185	250	324
SH-S * * * 640T		40	735	60.8	548	52.5	461	48.1	385	44.0	230	185	250	324
SH-S * * * 645T		45	827	68.4	617	59.0	518	54.1	433	49.5	230	185	250	324
SH-S * * * 650T		50	918	76.0	685	65.6	576	60.1	481	55.0	300	185	250	324
SH-S * * * 655T		55	1010	83.6	754	72.2	633	66.2	529	60.5	300	185	250	324
SH-S * * * 660T		60	1102	91.2	822	78.7	691	72.2	577	66.0	300	185	250	324
SH-L * * * 665T		65	1194	98.8	891	85.3	748	78.2	626	71.5	350	140	470	544
SH-L * * * 670T		70	1286	106.4	959	91.9	806	84.2	674	77.0	350	140	470	544
SH-L * * * 675T		75	1378	114.0	1028	98.4	863	90.2	722	82.5	350	140	470	544
SH-L * * * 680T		80	1470	121.6	1096	105.0	921	96.2	770	88.0	350	140	470	544
SH-L * * * 685T		85	1561	129.1	1165	111.5	979	102.2	818	93.5	350	140	470	544
SH-L * * * 690T		90	1653	136.7	1233	118.1	1036	108.3	866	99.0	350	140	470	544
SH-L * * * 6100T		100	1837	151.9	1370	131.2	1151	120.3	962	110.0	420	140	470	544
SH-L * * * 6120T		120	---	---	1644	157.5	1382	144.3	1155	132.0	420	140	470	544

- Applicable Environment**
- System voltage:380V , with 480V, 525V or above capacitor.
 - capacitor control led by APFR or parallel connected capacitors and high harmonic, series reactor L=6%, 7%, 13%,15% .
 - System voltage:380V , with 440V or above capacitor.
 - capacitor control led by APFR or parallel connected capacitors and high harmonic, series reactor L=6% .
 - System voltage:380V , with 380V or above capacitor.
 - Capacitors equipped with traditional manual on/off switch. Installed separately, seldom on/off, and no harmonic load.

· Type *** capacitor's rated voltage. For voltage 380 ~ 525 VAC, the dimension dose not change for 5 、 10 、 20 KVAR. The capacitors with 15 、 25~60KVAR capacity are smaller size models.

· Series reactors must be used In situations of using APFR control and high harmonic current. Suggest selected capacitor's rated voltage 1.25 times above system voltage. Please contact manufacturer for other special voltage or capacity capacitors.

(2) Low voltage dry-type oval-shaped power capacitor KJ with explode-proof and improved power factor features.

Characteristic

- The capacitor is made with high-voltage endurance and excellent dielectric metallized polypropylene film. It provides self-restoring function, when the film breaks, the metallized electrode around the spark hole will be evaporated and recovers insulation at the same time, hence the capacitor can still work normally.
- The capacitor is sealed in a aluminium shell. The inside medium and outer aluminium case touch each other provide good heat dissipation which make slow temperature rise and long operation life.
- The capacitor uses see-through insulation protective cover. It is easy to check any problem on screws and contact wires.
- Double protection function and high safety assurance. Inside each capacitor element installed with fuse and whole unit installed with protection device which effectively reduce disaster.
- Electric bill greatly reduced by low loss medium, slow temperature rise, long operation life, and slow capacity decay.
- The capacitor is equipped with discharge resistors to ensure the safety of usage and maintenance.
- This is a special Eco-friendly product made by shinlin. It use flame retardant resin and seal, the leakage of oil can be prevented so does the pollution of environment.
- Patent NO. 185576. Use fuse and pressure type protective device to provide double protection.
- First level protection provided by fuse. Fuse on each capacitor element break instantly at short-circuit to protect from current surge.
- Second level protection provided by protecting device. A pressure-activate protective device guard capacitor unit from over-pressure caused by self-restoring and penetrating.

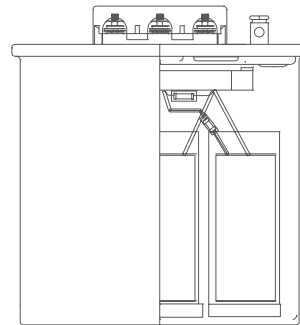

The capacitor is made with high-voltage endurance and excellent dielectric metallized

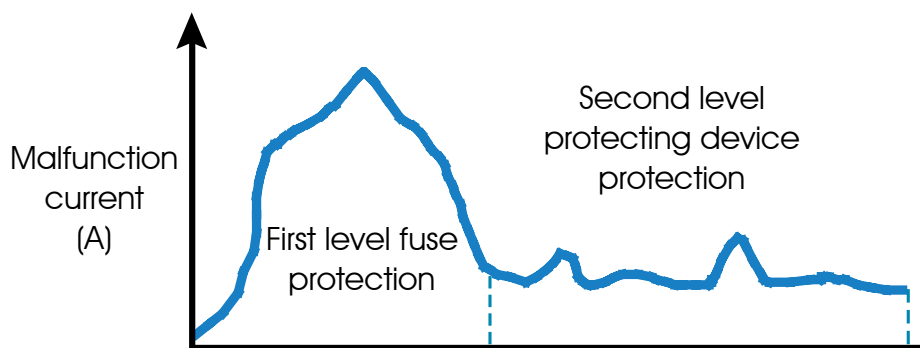

First level fuse protection : When sudden short-circuit occurs in the the capacitor, the substantial current produced will break the fuse.

Second level protection : The heat and gas produced from self-restoring ability of the capacitor will activate the pressurized protecting device.

Main technical target

- Application environment: indoor, ambient temperature $-25^{\circ}\text{C} \sim +45^{\circ}\text{C}$, humidity $\leq 95\%$, below 2000m
- Frequency : 60Hz ◦
- Capacity tolerance : $-5\% \sim +10\%$ (phase-to-phase deviation tolerance within $\pm 3\%$)
- Dielectric Strength : T-T 2.15VAC, T-C 3000V 10sec
- Medium loss: below 0.2W/KVAR ◦
- Max. permissible over voltage : rated voltage*110% (intermittent usage)
- Max. permissible over current : rated current*130%
- Discharge characteristic: each capacitor unit has discharge resistor which reduces the terminal voltage to under 50V within 1 minute after the capacitor has disconnected from power source.
- standard : IEC 831 、UL810 、JIS 4901 、UL810 、GB12747-91

Dimensions Diagram



Low voltage power capacitor selection table

3 ϕ 60Hz system voltage : 220VAC

Type	Rating Voltage (VAC)	Capacity & current			terminal	Dimensions(mm)						Applicable Environment
		Capacity KVAR	Capacity (μ F)	Current (A)		A	B	C	D	E	F	
SH-J220605T	220	5	274	13.1	M6	183	66	130	165	207	225	<ul style="list-style-type: none"> ● system voltage:220V with 260V or above capacitor. · capacitor control led by APFR or parallel connected capacitors and high harmonic, series reactor L=6%, 8%, 13%,15% . ● system voltage:220V with 240V or above capacitor. · capacitor control led by APFR or parallel connected capacitors and high harmonic, series reactor L=6% . ● system voltage:220V with 240V or above capacitor. · Capacitors equipped with traditional manual on/off switch. Installed separately, seldom on/off, and no harmonic load.
SH-J220610T		10	548	26.2	M6	183	66	200	235	207	225	
SH-J220615T		15	822	39.4	M8	250	100	200	235	274	292	
SH-J220620T		20	1096	52.5	M8	250	100	200	235	274	292	
SH-J220625T		25	1370	65.6	M8	250	100	200	235	274	292	
SH-J240605T	240	5	230	12.0	M6	183	66	130	165	207	225	
SH-J240610T		10	461	24.1	M6	183	66	200	235	207	225	
SH-J240615T		15	691	36.1	M8	250	100	200	235	274	292	
SH-J240620T		20	921	48.1	M8	250	100	200	235	274	292	
SH-J240625T		25	1151	60.1	M8	250	100	200	235	274	292	
SH-J260605T	260	5	196	11.1	M6	183	66	130	165	207	225	
SH-J260610T		10	392	22.2	M6	183	66	200	235	207	225	
SH-J260615T		15	589	33.3	M8	250	100	200	235	274	292	
SH-J260620T		20	785	44.4	M8	250	100	200	235	274	292	
SH-J260625T		25	981	55.5	M8	250	100	200	235	274	292	

3 ϕ 60Hz system voltage : 380VAC

Type	Rating Voltage (VAC)	Capacity & current			terminal	Dimensions(mm)						Applicable Environment
		Capacity KVAR	Capacity (μ F)	Current (A)		A	B	C	D	E	F	
SH-J380605T	380	5	92	7.6	M6	183	66	130	165	207	225	<ul style="list-style-type: none"> ● system voltage:380V with 440V or above capacitor · capacitor control led by APFR or parallel connected capacitors and high harmonic, series reactor L=6%, 8%, 13%,15% . ● system voltage:380V with 400V or above capacitor. · capacitor control led by APFR or parallel connected capacitors and high harmonic, series reactor L=6% . ● system voltage:380V with 380V or above capacitor. · Capacitors equipped with traditional manual on/off switch. Installed separately, seldom on/off, and no harmonic load.
SH-J380610T		10	184	15.2	M6	183	66	130	165	207	225	
SH-J380615T		15	276	22.8	M6	183	66	200	235	207	225	
SH-J380620T		20	367	30.4	M6	183	66	200	235	207	225	
SH-J380625T		25	459	38.0	M8	250	100	200	235	274	292	
SH-J380630T	30	551	45.6	M8	250	100	200	235	274	292		
SH-J400605T	400	5	83	7.2	M6	183	66	130	165	207	225	
SH-J400610T		10	166	14.4	M6	183	66	130	165	207	225	
SH-J400615T		15	249	21.7	M6	183	66	200	235	207	225	
SH-J400620T		20	332	28.9	M6	183	66	200	235	207	225	
SH-J400625T		25	414	36.1	M8	250	100	200	235	274	292	
SH-J400630T	30	497	43.3	M8	250	100	200	235	274	292		
SH-J440605T	440	5	69	6.6	M6	183	66	130	165	207	225	
SH-J440610T		10	137	13.1	M6	183	66	130	165	207	225	
SH-J440615T		15	206	19.7	M6	183	66	200	235	207	225	
SH-J440620T		20	274	26.2	M6	183	66	200	235	207	225	
SH-J440625T		25	343	32.8	M8	250	100	200	235	274	292	
SH-J440630T	30	411	39.4	M8	250	100	200	235	274	292		

(3) Low voltage dry-type cylinder-shaped power capacitor KR with explode-proof and improved power factor features.

Features

- The capacitor is made with high-voltage endurance and excellent dielectric metallized polypropylene film. It provides self-restoring function, when the film breaks, the metallized electrode around the spark hole will be evaporated and recovers insulation at the same time, hence the capacitor can still work normally.
- The capacitor is sealed in a aluminium shell. The inside medium and outer aluminum case touch each other provide good heat dissipation which make slow temperature rise and long operation life.
- The capacitor is uses see-through insulation protective cover. It is easy to check any problem on screws and contact wires.
- Double protection function and high safety assurance. Inside each capacitor element installed with fuse and whole unit installed with protection device which effectively reduce disaster.
- Electric bill greatly reduced by low loss medium, slow temperature rise, long operation life, and slow capacity decay.
- The capacitor is equipped with discharge resistors to ensure the safety of usage and maintenance.
- This is a special Eco-friendly product made by shinlin. It use flame retardant resin and seal, hence the leakage of oil can be prevented so does the pollution of environment.
- Save space in a cylindrical shell.
- Safe to rise and wait again.
- First level protection provided by fuse. Fuse on each capacitor element break instantly at short-circuit to protect from current surge.
- Second level protection provided by protecting device. A pressure-activate protective device guard capacitor unit from over-pressure caused by self-restoring and penetrating.

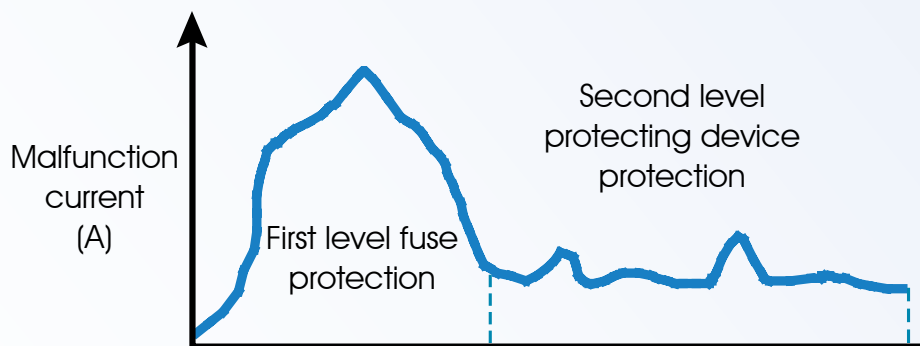
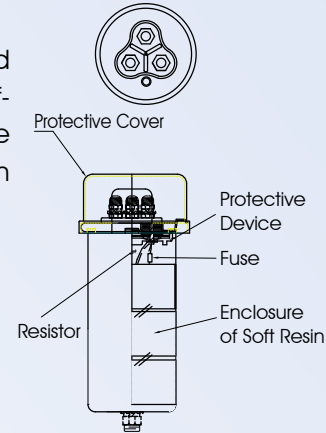

First level fuse protection : When sudden short-circuit occurs in the the capacitor, the substantial current produced will break the fuse.

Second level protection : The heat and gas produced from self-restoring ability of the capacitor will activate the pressurized protecting device.

Main technical target

- Application environment: indoor, ambient temperature $-25^{\circ}\text{C}\sim +45^{\circ}\text{C}$, humidity $\leq 95\%$, below 2000m
- Frequency : 60Hz °
- capacity tolerance : $-5\%\sim +10\%$ (phase-to-phase deviation tolerance within $\pm 3\%$)
- Dielectric Strength : T-T 2.15VAC,T-C 3000V 10sec
- Medium loss: below 0.2W/KVAR °
- Max. permissible over voltage : rated voltage*110% (intermittent usage)
- Max. permissible over current : rated current*130%
- Discharge characteristic:there is an internal resistor which discharge the remaining charge to less than 50volts after one minute.
- standard : IEC 831 、GB12747-91 、JIS 4901 、CNS1179,3738 、UL810



Dimensions Diagram

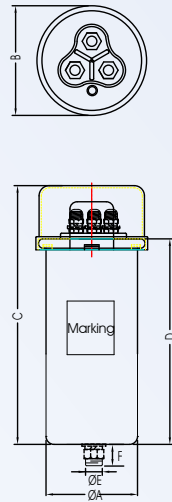

Low voltage power capacitor selection table 3Ø ,60Hz, System voltage220VAC

Type	Capacitor rated voltage (VAC)	Capacitance and Current			Terminal type	Dimensions(mm)						Applicable Environment
		Capacity KVAR	Capacitance (μF)	Current (A)		A	B	C	D	E	F	
SH-R260605T	260	5	196	11.1	M6	70	74	317	280	12	15	<ul style="list-style-type: none"> ● system voltage:220V · with 260V or above capacitor · capacitor control led by APFR or parallel connected capacitors, series reactor L=6% °
SH-R260610T		10	392	22.2	M6	70	74	317	280	12	15	
SH-R260615T		15	589	33.3	M8	116	120	327	280	16	25	
SH-R260620T		20	785	44.4	M8	116	120	327	280	16	25	

Low voltage power capacitor guiding table 3Ø,60Hz, System voltage380VAC

Type	Capacitor rated voltage (VAC)	Capacitance and Current			Terminal type	Dimensions(mm)						Applicable Environment
		Capacity KVAR	Capacitance (μF)	Current (A)		A	B	C	D	E	F	
SH-R440605T	440	5	69	6.6	M6	70	74	317	280	12	15	<ul style="list-style-type: none"> ● system voltage:380V with 260V or above capacitor · capacitor controlled by APFR or parallel connected capacitors, series reactor L=6% °
SH-R440610T		10	137	13.1	M6	70	74	317	280	12	15	
SH-R440615T		15	206	19.7	M6	70	74	317	280	12	15	
SH-R440620T		20	274	26.2	M8	116	120	327	280	16	25	
SH-R440625T		25	343	32.8	M8	116	120	327	280	16	25	
SH-R440630T		30	411	39.4	M8	116	120	327	280	16	25	

· Series reactors must be used in situations of using APFR control and high harmonic current. Suggest selected capacitor's rated voltage 1.25 times above system voltage. Please contact manufacturer for other special voltage or capacity capacitors.

(4) Low Voltage Anti-Harmonic Capacitor KH Series

Electric system quality deteriorates in recent years due to the rapid electronic industry development and vast applications. The existence of Harmonic affects both system operation and safety of equipment. It became an non-ignorable factor regards of safety issues and the damages to the electric system.

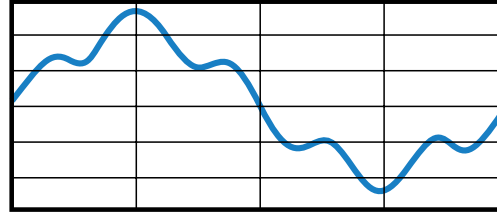

The deterioration of power quality has caused unpredictable accidents from time to time so that capacitor has become the biggest victim. Therefore the choice of application environment and capacitor specification has to be more careful than ever. Hence, Shihlin produce Anti-Harmonic capacitors which meet customer's needs to ensure the system operation safety and also to reduce damage. This product has the following favorable features:

1. Protect the electric devices from being damaged by the harmonic.
2. Keep the electric system running normally in poor electricity supply.
3. Avoid the relative damage.

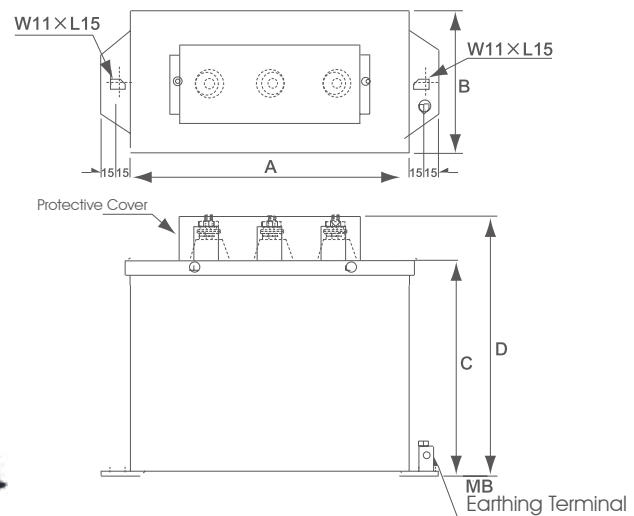

3Ø · 60Hz

Type	Rated Voltage	Capacity		Current(A)	Dimensions(mm)			
		KVAR	μ F		A	B	C	D
SH-H220610T	220V	10	548	26.2	230	130	250	324
SH-H220615T		15	822	39.4	230	185	250	324
SH-H220620T		20	1096	52.5	300	185	250	324
SH-H220625T		25	1370	65.6	300	185	250	324
SH-H220630T		30	1644	78.7	300	240	250	324
SH-H220635T		35	1918	91.9	350	140	470	544
SH-H220640T		40	2192	105.0	420	140	470	544
SH-H220645T		45	2466	118.1	420	140	470	544
SH-H220650T		50	2740	131.2	420	140	470	544
SH-H380610T		380V	10	183.7	15.2	230	130	250
SH-H380615T	15		275.5	22.8	230	130	250	324
SH-H380620T	20		367.4	30.4	230	185	250	324
SH-H380625T	25		459.2	38.0	230	185	250	324
SH-H380630T	30		551.1	45.6	300	185	250	324
SH-H380635T	35		642.9	53.2	300	240	250	324
SH-H380640T	40		734.8	60.8	300	240	250	324
SH-H380645T	45		826.6	68.4	350	140	470	544
SH-H380650T	50		918.5	76.0	350	140	470	544
SH-H440610T	440V		10	137	13.1	230	130	250
SH-H440615T		15	206	19.7	230	130	250	324
SH-H440620T		20	274	26.2	230	185	250	324
SH-H440625T		25	343	32.8	230	185	250	324
SH-H440630T		30	411	39.4	300	185	250	324
SH-H440635T		35	480	45.9	300	240	250	324
SH-H440640T		40	548	52.5	300	240	250	324
SH-H440645T		45	617	59.0	350	140	470	544
SH-H440650T		50	685	65.6	350	140	470	544
SH-H480610T		480V	10	115.1	12.0	230	130	250
SH-H480615T	15		172.7	18.0	230	130	250	324
SH-H480620T	20		230.3	24.1	230	185	250	324
SH-H480625T	25		287.8	30.1	230	185	250	324
SH-H480630T	30		345.4	36.1	300	185	250	324
SH-H480635T	35		402.9	42.1	300	240	250	324
SH-H480640T	40		460.5	48.1	300	240	250	324
SH-H480645T	45		518.1	54.1	350	140	470	544
SH-H480650T	50		575.6	60.1	350	140	470	544
SH-H525610T	525V		10	96.2	11.0	230	130	250
SH-H525615T		15	144.4	16.5	230	130	250	324
SH-H525620T		20	192.5	22.0	230	185	250	324
SH-H525625T		25	240.6	27.5	230	185	250	324
SH-H525630T		30	288.7	33.0	300	185	250	324
SH-H525635T		35	336.8	38.5	300	240	250	324
SH-H525640T		40	384.9	44.0	300	240	250	324
SH-H525645T		45	433.1	49.5	350	140	470	544
SH-H525650T		50	481.2	55.0	350	140	470	544

(5) μ F Type Indoor Capacitor Series

features

- The capacitor is made with high-voltage endurance and excellent dielectric metallized polypropylene film. It provides self-restoring function, when the film breaks, the metallized electrode around the spark hole will be evaporated and recovers insulation at the same time, hence the capacitor can still work normally.
- The capacitor is sealed in the aluminium shell. Inside medium and aluminum case touch each other provide good heat dissipation which make slow temperature rise and long operation life.
- Reliable and high safety assurance. It utilizes over-pressure protecting device to effectively reduce and isolate damages.
- Electric bill greatly reduced by low loss medium, slow temperature rise, long operation life, and slow capacity decay.
- The capacitor is equipped with discharge resistors to ensure the safety of usage and maintenance.
- This is a special Eco-friendly product made by shinlin and use flame retardant resin and seal, hence the leakage of oil can be prevented so does the pollution of environment.

Main technical target

- Application environment: indoor, ambient temperature $-25^{\circ}\text{C} \sim +45^{\circ}\text{C}$, humidity $\leq 95\%$, below 2000m
- Frequency : 60Hz °
- Capacity tolerance : $-5\% \sim +10\%$ (phase-to-phase deviation tolerance within $\pm 3\%$)
- Dielectric Strength : T-T 2.15VAC, T-C 3000V 10sec
- Medium loss: below 0.2W/KVAR °
- Max. permissible over voltage : rated voltage*110% (intermittent usage)
- Max. permissible over current : rated current*130%
- Discharge characteristic: there is an internal resistor which discharge the remaining charge to less than 50volts after one minutes.
- Standard : IEC 831 、GB12747-91 、JIS 4901 、CNS1179,3738 、UL810

Diagram of Dimensions

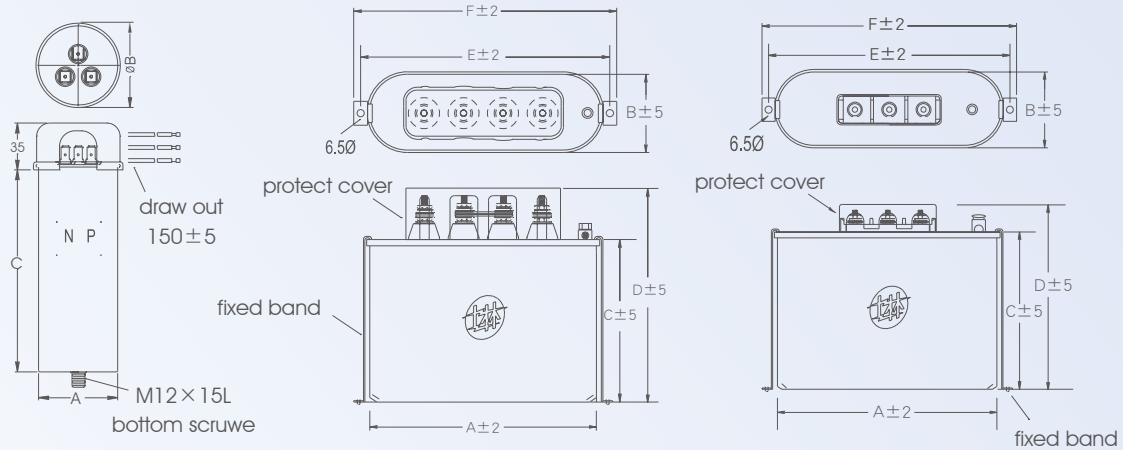

Fig. A

Fig. B

Fig. C

60Hz

Type	(VAC)						draw out terminal	dimension (mm)						fig.
		Phase	capacity KVAR	capacity (μF)	3 φ current (A)	1 φ current (A)		A	B	C	D	E	F	
SH-UR220100T		3 φ	1.8	100	4.8	---	12AWG	65	67	230	---	---	---	A
SH-UR220150T		3 φ	2.7	150	7.2	---	12AWG	65	67	230	---	---	---	A
SH-UR220200T		3 φ	3.6	200	9.6	---	12AWG	65	67	230	---	---	---	A
SH-UJ220250ST	220	1/3 φ	4.6	250	12.0	20.7	M6	183	66	130	165	207	225	B
SH-UJ220300ST		1/3 φ	5.5	300	14.4	24.9	M6	183	66	130	165	207	225	B
SH-UJ220400ST		1/3 φ	7.3	400	19.2	33.2	M6	183	66	180	215	207	225	B
SH-UJ220500ST		1/3 φ	9.1	500	23.9	41.5	M6	183	66	180	215	207	225	B
SH-UR380100T		3 φ	5.4	100	8.3	---	12AWG	65	67	230	---	---	---	A
SH-UJ380150ST		1/3 φ	8.2	150	12.4	21.5	M6	183	66	130	165	207	225	B
SH-UJ380200ST		1/3 φ	10.9	200	16.5	28.7	M6	183	66	130	165	207	225	B
SH-UJ380250ST	380	1/3 φ	13.6	250	20.7	35.8	M6	183	66	180	215	207	225	B
SH-UJ380300ST		1/3 φ	16.3	300	24.8	43.0	M6	183	66	180	215	207	225	B
SH-UJ380400T		3 φ	21.8	400	33.1	---	M8	250	100	200	235	274	292	C
SH-UJ380500T		3 φ	27.2	500	41.4	---	M8	250	100	200	235	274	292	C
SH-UR440100T		3 φ	7.3	100	9.6	16.6	12AWG	65	67	230	---	---	---	A
SH-UJ440150ST		1/3 φ	10.9	150	14.4	24.9	M6	183	66	130	165	207	225	B
SH-UJ440200ST		1/3 φ	14.6	200	19.2	33.2	M6	183	66	180	215	207	225	B
SH-UJ440250ST	440	1/3 φ	18.2	250	23.9	41.5	M6	183	66	180	215	207	225	B
SH-UJ440300T		3 φ	21.9	300	28.7	---	M8	250	100	200	235	274	292	C
SH-UJ440400T		3 φ	29.2	400	38.3	---	M8	250	100	200	235	274	292	C
SH-UJ440500T		3 φ	36.5	500	47.9	---	M8	250	100	200	235	274	292	C

Series reactors must be used in situations of using APFR control and high harmonic current. Suggest selected capacitor's rated voltage 1.25 times above system voltage. Please contact manufacturer for other special voltage or capacity capacitors.

(6) Low voltage power dry type H level series reactor

Advantages of series reactor

- Series reactor can suppress high frequency surge caused by capacitor power switching.
- Series reactor can suppress over-voltage caused by repeated arc at instance of capacitor switch off.
- Series reactor can change system impedance, suppress harmonic voltage and current.

Application

- It can be connected to series capacitors to reduce or suppress sudden increase of capacitor current.
- Application environment: below 1000m, ambient temperature below 40°C, average temperature in 24 hours does not over 35°C
- standard : JEC-2210(1990)
- Temperature rise: continuous rated current 135% , coil temperature does not to outstrip 120°C °
- dielectric withstand voltage: AC 4000V/min °
- Max safety current: 5th harmonic current contain below 35%, compound current below 120%.
- Reactor insulation level: H level. Protection level: IPOO



Dimension Diagram

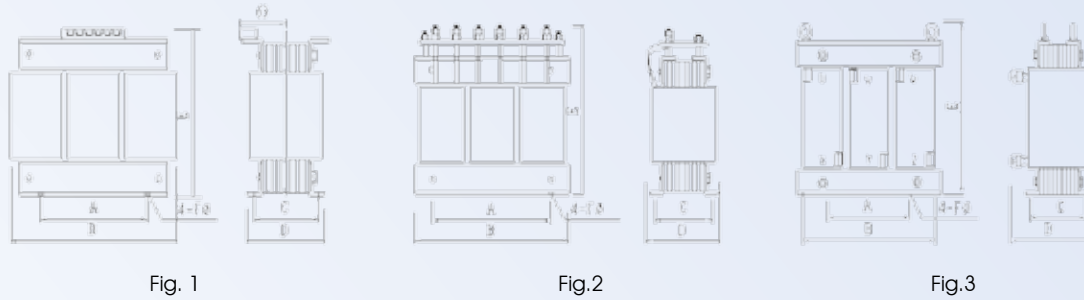

3Ø , 60Hz , System voltage : 220VAC

Rating capacity (KVAR)	Type	resistor rating voltage (VAC)	6% Resistor capacity (KVAR)	Dimensions(mm)						weight (kg)	Fig	Remark
				A	B	C	D	E	F			
240 VAC	5 SR6-24060030T	240	0.3	65	150	85	100	140	8	4.8	1	<ul style="list-style-type: none"> ● Capacitors controlled by APFR or multiple parallel connected capacitors under low system harmonics. ● If 6% reactor series connected to capacitors, the capacitor's terminal voltage will increase 1/ (1-6%) [about 1.064 times]. It is suggested to upgrade capacitor's withstand voltage, select capacitor with rated voltage above 240V.
	10 SR6-24060060T	240	0.6	90	200	80	110	220	8	10.0	2	
	15 SR6-24060090T	240	0.9	90	200	90	120	220	8	11.5	2	
	20 SR6-24060120T	240	1.2	90	200	100	130	220	8	13.0	2	
	25 SR6-24060150T	240	1.5	90	200	110	140	220	8	15.0	2	
	30 SR6-24060180T	240	1.8	160	250	100	200	220	10	19.0	3	
	35 SR6-24060210T	240	2.1	160	250	110	210	220	10	21.0	3	
	40 SR6-24060240T	240	2.4	160	250	120	215	220	10	24.0	3	
	45 SR6-24060270T	240	2.7	160	250	130	230	220	10	26.0	3	
	50 SR6-24060300T	240	3.0	180	285	125	220	250	14	31.0	3	
	60 SR6-24060360T	240	3.6	180	285	130	230	250	14	34.0	3	
70 SR6-24060420T	240	4.2	180	320	135	240	285	14	42.0	3		
75 SR6-24060450T	240	4.5	180	320	135	250	285	14	43.0	3		
80 SR6-24060480T	240	4.8	180	320	135	250	285	14	44.0	3		
260 VAC	5 SR6-26060030T	260	0.3	65	150	85	100	140	8	4.8	1	<ul style="list-style-type: none"> ● Capacitors controlled by APFR or multiple parallel connected capacitors under low system harmonics. ● If capacitor series connected to 6%, 7%, 8%, 13% reactor, capacitor's terminal voltage will increase 1/ (1-L%) times. It is suggested to upgrade capacitor's withstand voltage level, select capacitor with rated voltage above 260V.
	10 SR6-26060060T	260	0.6	90	200	80	110	220	8	10.0	2	
	15 SR6-26060090T	260	0.9	90	200	90	120	220	8	11.5	2	
	20 SR6-26060120T	260	1.2	90	200	100	130	220	8	13.0	2	
	25 SR6-26060150T	260	1.5	90	200	110	140	220	8	15.0	2	
	30 SR6-26060180T	260	1.8	160	250	100	160	260	10	19.0	2	
	35 SR6-26060210T	260	2.1	160	250	110	210	220	10	21.0	3	
	40 SR6-26060240T	260	2.4	160	250	120	215	220	10	24.0	3	
	45 SR6-26060270T	260	2.7	160	250	130	230	220	10	26.0	3	
	50 SR6-26060300T	260	3.0	180	285	125	220	250	14	31.0	3	
	60 SR6-26060360T	260	3.6	180	285	130	230	250	14	34.0	3	
70 SR6-26060420T	260	4.2	180	320	135	240	285	14	42.0	3		
75 SR6-26060450T	260	4.5	180	320	135	250	285	14	43.0	3		
80 SR6-26060480T	260	4.8	180	320	135	250	285	14	44.0	3		

3Ø , 60Hz , System voltage : 380VAC

Rating capacity (KVAR)	Type	resistor rating voltage (VAC)	6% Resistor capacity (KVAR)	Dimensions(mm)						weight (kg)	Fig	Remark	
				A	B	C	D	E	F				
440 VAC	5	SR6-44060030T	440	0.3	65	150	85	100	140	8	4.8	1	<ul style="list-style-type: none"> ● Capacitors controlled by APFR or multiple parallel connected capacitors under low system harmonics. ● If 6% reactor series connected to capacitors, the capacitor's terminal voltage will increase 1/(1-6%) [about 1.064 times]. It is suggested to upgrade capacitor's withstand voltage, select capacitor with rated voltage above 440V.
	10	SR6-44060060T	440	0.6	90	200	80	110	220	8	10.0	2	
	15	SR6-44060090T	440	0.9	90	200	90	120	220	8	11.5	2	
	20	SR6-44060120T	440	1.2	90	200	100	130	220	8	13.0	2	
	25	SR6-44060150T	440	1.5	90	200	110	140	220	8	15.0	2	
	30	SR6-44060180T	440	1.8	160	250	100	160	260	10	19.0	2	
	35	SR6-44060210T	440	2.1	160	250	110	170	260	10	21.0	2	
	40	SR6-44060240T	440	2.4	160	250	120	180	260	10	24.0	2	
	45	SR6-44060270T	440	2.7	160	250	130	190	260	10	26.0	2	
	50	SR6-44060300T	440	3.0	180	285	125	220	250	14	31.0	3	
	60	SR6-44060360T	440	3.6	180	285	130	230	250	14	34.0	3	
	70	SR6-44060420T	440	4.2	180	320	135	240	285	14	42.0	3	
75	SR6-44060450T	440	4.5	180	320	135	250	285	14	43.0	3		
80	SR6-44060480T	440	4.8	180	320	135	250	285	14	44.0	3		
90	SR6-44060540T	440	5.4	180	320	135	250	285	14	46.0	3		
100	SR6-44060600T	440	6.0	180	320	150	260	285	14	51.0	3		
120	SR6-44060720T	440	7.2	180	320	150	270	285	14	55.0	3		
460 VAC	5	SR6-46060030T	460	0.3	65	150	85	100	140	8	4.8	1	<ul style="list-style-type: none"> ● Capacitors controlled by APFR or multiple parallel connected capacitors under low system harmonics. ● If capacitor series connected to 6%, 7% reactor, capacitor's terminal voltage will increase 1/(1-L%) times. It is suggested to upgrade capacitor's withstand voltage level, select capacitor with rated voltage above 460V.
	10	SR6-46060060T	460	0.6	90	200	80	110	220	8	10.0	2	
	15	SR6-46060090T	460	0.9	90	200	90	120	220	8	11.5	2	
	20	SR6-46060120T	460	1.2	90	200	100	130	220	8	13.0	2	
	25	SR6-46060150T	460	1.5	90	200	110	140	220	8	15.0	2	
	30	SR6-46060180T	460	1.8	160	250	100	160	260	10	19.0	2	
	35	SR6-46060210T	460	2.1	160	250	110	170	260	10	21.0	2	
	40	SR6-46060240T	460	2.4	160	250	120	180	260	10	24.0	2	
	45	SR6-46060270T	460	2.7	160	250	130	190	260	10	26.0	2	
	50	SR6-46060300T	460	3.0	180	285	125	220	250	14	31.0	3	
	60	SR6-46060360T	460	3.6	180	285	130	230	250	14	34.0	3	
	70	SR6-46060420T	460	4.2	180	320	135	240	285	14	42.0	3	
75	SR6-46060450T	460	4.5	180	320	135	250	285	14	43.0	3		
80	SR6-46060480T	460	4.8	180	320	135	250	285	14	44.0	3		
90	SR6-46060540T	460	5.4	180	320	135	250	285	14	46.0	3		
100	SR6-46060600T	460	6.0	180	320	150	260	285	14	51.0	3		
120	SR6-46060720T	460	7.2	180	320	150	270	285	14	55.0	3		

Dimensions Diagram

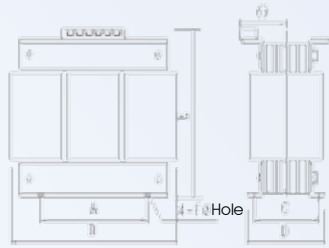

Fig. 1

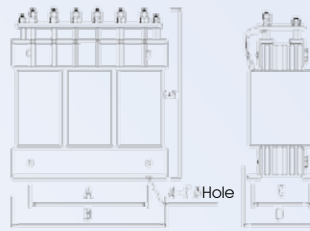

Fig.2

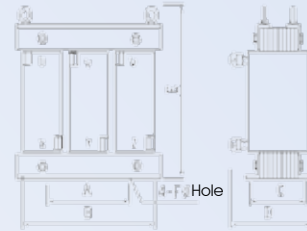

Fig. 3

3Ø , 60Hz , System voltage : 380 or 440 VAC

Rating capacity (KVAR)	Type	resistor rating voltage (VAC)	6% Resistor capacity (KVAR)	Dimensions(mm)						weight (kg)	Fig	Remark	
				A	B	C	D	E	F				
480 VAC	5	SR6-48060030T	480	0.3	65	150	85	100	140	8	4.8	1	<ul style="list-style-type: none"> ● Capacitors controlled by APFR or multiple parallel connected capacitors under low system harmonics. ● If capacitor series connected to 6%, 7%, 8%, 13% reactor, capacitor's terminal voltage will increase 1/(1-L%) times. It is suggested to upgrade capacitor's withstand voltage level, select capacitor with rated voltage above 480V.
	10	SR6-48060060T	480	0.6	90	200	80	110	220	8	10.0	2	
	15	SR6-48060090T	480	0.9	90	200	90	120	220	8	11.5	2	
	20	SR6-48060120T	480	1.2	90	200	100	130	220	8	13.0	2	
	25	SR6-48060150T	480	1.5	90	200	110	140	220	8	15.0	2	
	30	SR6-48060180T	480	1.8	160	250	100	160	260	10	19.0	2	
	35	SR6-48060210T	480	2.1	160	250	110	170	260	10	21.0	2	
	40	SR6-48060240T	480	2.4	160	250	120	180	260	10	24.0	2	
	45	SR6-48060270T	480	2.7	160	250	130	190	260	10	26.0	2	
	50	SR6-48060300T	480	3.0	180	285	125	220	250	14	31.0	3	
	60	SR6-48060360T	480	3.6	180	285	130	230	250	14	34.0	3	
	70	SR6-48060420T	480	4.2	180	320	135	240	285	14	42.0	3	
75	SR6-48060450T	480	4.5	180	320	135	250	285	14	43.0	3		
80	SR6-48060480T	480	4.8	180	320	135	250	285	14	44.0	3		
90	SR6-48060540T	480	5.4	180	320	135	250	285	14	46.0	3		
100	SR6-48060600T	480	6.0	180	320	150	260	285	14	51.0	3		
120	SR6-48060720T	480	7.2	180	320	150	270	285	14	55.0	3		
525 VAC	5	SR6-52560030T	525	0.3	65	150	85	100	140	8	4.8	1	<ul style="list-style-type: none"> ● Capacitors controlled by APFR or multiple parallel connected capacitors under low system harmonics. ● If capacitor series connected to 6%, 7% reactor, capacitor's terminal voltage will increase 1/(1-L%) times. It is suggested to upgrade capacitor's withstand voltage level, select capacitor with rated voltage above 525V.
	10	SR6-52560060T	525	0.6	90	200	80	110	220	8	10.0	2	
	15	SR6-52560090T	525	0.9	90	200	90	120	220	8	11.5	2	
	20	SR6-52560120T	525	1.2	90	200	100	130	220	8	13.0	2	
	25	SR6-52560150T	525	1.5	90	200	110	140	220	8	15.0	2	
	30	SR6-52560180T	525	1.8	160	250	100	160	260	10	19.0	2	
	35	SR6-52560210T	525	2.1	160	250	110	170	260	10	21.0	2	
	40	SR6-52560240T	525	2.4	160	250	120	180	260	10	24.0	2	
	45	SR6-52560270T	525	2.7	160	250	130	190	260	10	26.0	2	
	50	SR6-52560300T	525	3.0	180	285	125	220	250	14	31.0	3	
	60	SR6-52560360T	525	3.6	180	285	130	230	250	14	34.0	3	
	70	SR6-52560420T	525	4.2	180	320	135	240	285	14	42.0	3	
75	SR6-52560450T	525	4.5	180	320	135	250	285	14	43.0	3		
80	SR6-52560480T	525	4.8	180	320	135	250	285	14	44.0	3		
90	SR6-52560540T	525	5.4	180	320	135	250	285	14	46.0	3		
100	SR6-52560600T	525	6.0	180	320	150	260	285	14	51.0	3		
120	SR6-52560720T	525	7.2	180	320	150	270	285	14	55.0	3		

(7) The selection Of Series Reactor After Increase Of Capacitor Voltage



Wrong selection
System Voltage 220V

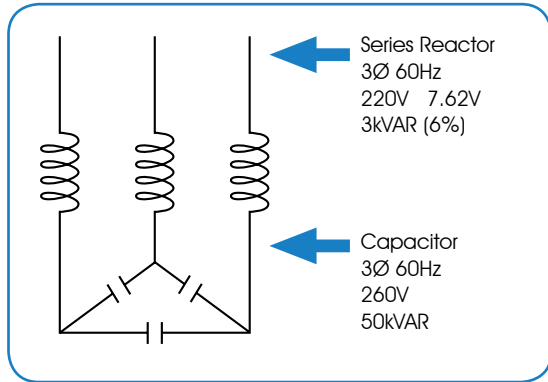

The rated voltages of reactor and capacitor are different, the ratio of impedance is 4.3% (not 6%)



Correct selection
System Voltage 260V

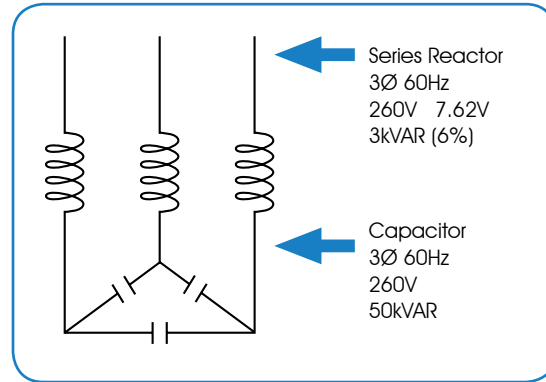

The rated voltages of reactor and capacitor are the same, the ratio of impedance is 6%

Calculation of the Capacitance and Reactance ratio

$$\begin{aligned} (220V/\sqrt{3}) \times 6\% &= 7.62V \\ XL = V^2/Q &= 7.62^2/3KVAR/3 = 0.0581 \Omega \\ XC = V^2/Q &= 260^2/50KVAR = 1.352 \Omega \\ XL/XC &= 0.0581/1.352 = 4.3\% \end{aligned}$$

$$\begin{aligned} (260V/\sqrt{3}) \times 6\% &= 9.01V \\ XL = V^2/Q &= 9.01^2/3KVAR/3 = 0.0811 \Omega \\ XC = V^2/Q &= 260^2/50KVAR = 1.352 \Omega \\ XL/XC &= 0.0811/1.352 = 6\% \end{aligned}$$

(8) Low Voltage Power Factor Improved Capacitors General Inspection And Diagnose

Break down check by visual inspection

Indoor type : If the Capacitor case lid open or internal fillings ejected, it means the capacitor is broken.

Basic function inspection

First of all, the capacitor must be switched off at least 3 minutes , then phases to ground discharge followed by phase to phase discharge.

Capacitance is measured by digital reading capacitor meter

1.Half the rated capacitance printed on name plate or certificate is the phase to phase capacitance.

2.Identify phase: The U, V, W phases are identified from the name plate side.

3.The rated capacitance calculated by measured value

$$U-V = a (\mu F)$$

$$U-W = b (\mu F) \therefore (a + b + c) \times 2 \div 3 = \text{rated capacitance}$$

$$V-W = c (\mu F)$$

4.Determined by the rated capacitance

- Within -5% ~ +15% of rated capacitance.
- If multiple capacitor units are connected in parallel, the total capacitance is derived by one unit's capacitance times the number of units.
- If interphase unbalance ratio is < 108%.
Use the phase in lowest ratio then divided by other two phases individually and get percentage.



(9) Low Voltage Capacitor's Maintenance

Daily maintenance

1. The capacitor's ambient temperature must be lower 45°C, At installation consider following items: ambient temperature, ambient temperature rise, ventilation equipment, and heat source.
2. The condition of switches used in capacitor's protecting device must be checked to prevent poor contacting.
3. Inspect if applied voltage and current are normal. The capacitor's operation life will be shortened if it is used in over-voltage condition which causes capacitance increase, temperature rise, and also damage internal insulation elements due to abnormal voltage.
4. Check if any abnormal condition at connection wires and capacitor terminals.
5. Check for other abnormal situations.

Regular maintenance

1. After using capacitor for a long time, accumulated dusts on bushing must. Dusts mixed with moisture will reduce the insulation resistance and cause electricity leakage which may activate protective device. To clean bushing and to avoid electric shock, power to capacitor must be cut for 3 minutes and capacitor be fully discharged thru ground wire.
2. All capacitors must be cleaned and polished regularly to help release surface heat.

(10) Capacitance Coefficients Calculation Of The Capacitors To Be Installed

Example:

Load of the plant:500KW

Power factor before improvement:Cos $\theta_1=0.6$

Desired power factor after

improvement:Cos $\theta_2=0.95$

Capacitance of the capacitor required

=500*1.005 \approx 500KVAR

(Note:1.005 is obtained from the following table)

Conversion between KVAR and μF

$$C (\mu f) = \frac{KVAR \times 10^9}{2 \pi f E^2}$$

If 50Hz, $2 \pi f=314$

If 60 Hz, $2 \pi f=377$

In the above equation:

KVAR=Value of capacitance

f=Frequency Hz

E=Rated voltage V

Power factor before improvement	Cos θ_2 Power factor desired after improvement												
	Cos θ_1	0.80	0.85	0.90	0.91	0.92	0.93	0.94	0.95	0.96	0.97	0.98	0.99
0.50	0.982	1.112	1.248	1.276	1.303	1.337	1.369	1.403	1.441	1.481	1.529	1.590	1.732
0.51	0.936	1.066	1.202	1.230	1.257	1.291	1.323	1.357	1.395	1.435	1.483	1.544	1.686
0.52	0.894	1.024	1.160	1.188	1.215	1.249	1.281	1.315	1.353	1.393	1.441	1.502	1.644
0.53	0.850	0.980	1.116	1.144	1.171	1.205	1.237	1.271	1.309	1.349	1.397	1.458	1.600
0.54	0.809	0.939	1.075	1.103	1.130	1.164	1.196	1.230	1.268	1.308	1.356	1.417	1.559
0.55	0.769	0.899	1.035	1.063	1.090	1.124	1.156	1.190	1.228	1.268	1.316	1.377	1.519
0.56	0.730	0.860	0.996	1.024	1.051	1.085	1.117	1.151	1.189	1.229	1.277	1.338	1.480
0.57	0.692	0.822	0.958	0.986	1.013	1.047	1.079	1.113	1.151	1.191	1.239	1.300	1.442
0.58	0.655	0.785	0.921	0.949	0.976	1.010	1.042	1.076	1.114	1.154	1.202	1.263	1.405
0.59	0.618	0.748	0.884	0.912	0.939	0.973	1.005	1.039	1.077	1.117	1.165	1.226	1.368
0.60	0.584	0.714	0.849	0.878	0.905	0.939	0.971	1.005	1.043	1.083	1.131	1.192	1.334
0.61	0.549	0.679	0.815	0.843	0.870	0.904	0.936	0.970	1.008	1.048	1.096	1.157	1.299
0.62	0.515	0.645	0.781	0.809	0.836	0.870	0.902	0.936	0.974	1.014	1.062	1.123	1.265
0.63	0.483	0.613	0.749	0.777	0.804	0.838	0.870	0.904	0.942	0.982	1.030	1.091	1.233
0.64	0.450	0.580	0.716	0.744	0.771	0.805	0.837	0.871	0.909	0.949	0.997	1.058	1.200
0.65	0.419	0.549	0.685	0.713	0.740	0.774	0.804	0.840	0.878	0.918	0.966	1.027	1.169
0.66	0.388	0.518	0.654	0.682	0.709	0.743	0.775	0.809	0.847	0.887	0.935	0.996	1.138
0.67	0.358	0.488	0.624	0.652	0.679	0.713	0.745	0.779	0.817	0.857	0.905	0.966	1.108
0.68	0.329	0.459	0.595	0.623	0.650	0.684	0.716	0.750	0.788	0.826	0.876	0.937	1.079
0.69	0.299	0.429	0.565	0.593	0.620	0.654	0.686	0.720	0.758	0.798	0.840	0.907	1.049
0.70	0.270	0.400	0.536	0.564	0.591	0.625	0.657	0.691	0.729	0.769	0.811	0.878	1.020
0.71	0.242	0.372	0.508	0.536	0.563	0.597	0.629	0.663	0.701	0.741	0.783	0.850	0.992
0.72	0.213	0.343	0.479	0.507	0.534	0.568	0.600	0.634	0.672	0.712	0.754	0.821	0.963
0.73	0.186	0.316	0.452	0.480	0.507	0.541	0.573	0.607	0.645	0.685	0.727	0.794	0.936
0.74	0.159	0.289	0.425	0.453	0.480	0.514	0.546	0.580	0.618	0.658	0.700	0.767	0.909

Power factor before improvement	Cos θ_2 Power factor desired after improvement												
	Cos θ_1	0.80	0.85	0.90	0.91	0.92	0.93	0.94	0.95	0.96	0.97	0.98	0.99
0.75	0.132	0.262	0.398	0.426	0.453	0.487	0.519	0.553	0.591	0.631	0.673	0.740	0.882
0.76	0.105	0.235	0.371	0.399	0.426	0.460	0.492	0.526	0.564	0.604	0.652	0.713	0.855
0.77	0.079	0.209	0.345	0.373	0.400	0.434	0.466	0.500	0.538	0.578	0.620	0.687	0.829
0.78	0.053	0.183	0.319	0.347	0.374	0.408	0.440	0.474	0.512	0.552	0.594	0.661	0.803
0.79	0.026	0.156	0.292	0.320	0.347	0.381	0.413	0.447	0.485	0.525	0.567	0.634	0.776
0.80	-	0.130	0.266	0.294	0.321	0.355	0.387	0.421	0.459	0.499	0.541	0.608	0.750
0.81	-	0.104	0.240	0.268	0.295	0.329	0.361	0.395	0.433	0.473	0.515	0.582	0.724
0.82	-	0.078	0.214	0.242	0.269	0.303	0.335	0.369	0.407	0.447	0.489	0.556	0.698
0.83	-	0.052	0.188	0.216	0.243	0.277	0.309	0.343	0.381	0.421	0.463	0.530	0.672
0.84	-	0.026	0.162	0.190	0.217	0.251	0.283	0.317	0.355	0.395	0.437	0.504	0.645
0.85	-	-	0.136	0.164	0.191	0.225	0.257	0.291	0.329	0.369	0.417	0.473	0.620
0.86	-	-	0.109	0.140	0.167	0.198	0.230	0.264	0.301	0.343	0.390	0.450	0.593
0.87	-	-	0.083	0.114	0.141	0.172	0.204	0.238	0.275	0.317	0.364	0.424	0.567
0.88	-	-	0.054	0.085	0.112	0.143	0.175	0.209	0.246	0.288	0.335	0.395	0.538
0.89	-	-	0.028	0.059	0.086	0.117	0.149	0.183	0.230	0.262	0.309	0.369	0.512
0.90	-	-	-	0.031	0.058	0.089	0.121	0.155	0.192	0.234	0.281	0.341	0.484
0.91	-	-	-	-	0.027	0.058	0.090	0.124	0.161	0.203	0.250	0.310	0.453
0.92	-	-	-	-	-	0.031	0.063	0.097	0.134	0.176	0.223	0.283	0.426
0.93	-	-	-	-	-	-	0.032	0.066	0.103	0.145	0.192	0.252	0.395
0.94	-	-	-	-	-	-	-	0.034	0.071	0.113	0.160	0.220	0.363
0.95	-	-	-	-	-	-	-	-	0.037	0.079	0.126	0.186	0.329
0.96	-	-	-	-	-	-	-	-	-	0.042	0.089	0.149	0.292
0.97	-	-	-	-	-	-	-	-	-	-	0.047	0.107	0.250
0.98	-	-	-	-	-	-	-	-	-	-	-	0.060	0.203
0.99	-	-	-	-	-	-	-	-	-	-	-	-	0.143

(11) Low Voltage Capacitor Coefficient Variation Calculation After Voltage Increase

System Voltage	Intended increase of capacitor rated voltage												
	240	260	280	300	380	400	440	460	480	500	525	600	700
220	1,190	1,397	1,620	1,860	-	-	-	-	-	-	-	-	-
240	-	1,174	1,361	1,563	-	-	-	-	-	-	-	-	-
380	-	-	-	-	-	1,108	1,341	1,465	1,596	1,731	1,909	-	-
400	-	-	-	-	-	-	1,210	1,323	1,441	1,563	1,723	2,250	-
440	-	-	-	-	-	-	-	1,093	1,190	1,291	1,424	1,860	-
460	-	-	-	-	-	-	-	-	1,089	1,181	1,303	1,701	2,316

Example : Assuming the system voltage is 380V, the required capacitance is 100KVAR, considering the voltage increase due to series connected reactor and high harmonics, the capacitor rated voltage is proposed to increase to 440V. The conversion formula as follows:

Required capacitor capacitance = 100KVAR × 1.341 (obtained from above table) = 134.1 KVAR

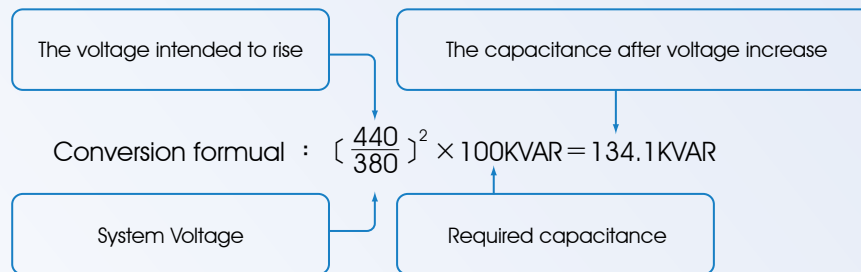



INTEGRATION OF POWER SYSTEM

www.seec.com.tw / www.seecusa.com

Head Office 16F, No.88, Sec.6, Chung Shan N. Rd., Taipei, 111 Taiwan
T. +886-2-2834-2662 F. +886-2-2836-6187

Export Sales Dept. 13F, No.90, Sec.6, Chung Shan N. Rd., Taipei, 111 Taiwan
T. +886-2-2832-1556 F. +886-2-2832-1003 e-mail: export@seec.com.tw

Heavy Electric Factory No. 23, Chung Hwa Rd., Hsin Chu Industrial Park, HsinChu, 303 Taiwan
T. +886-3-598-1921 F. +886-3-598-1480

Overseas Office
Shihlin Electric U.S.A. 80 South Lake Avenue, Suite 780, Pasadena, CA 91101
T. +1-626-535-0132 F. +1-626-535-0134 e-mail: sales@seecusa.com

Area Representative

2009, 2,000

Copyright reserved